

BXUV.W461

Design/System/Construction/Assembly Usage Disclaimer

- Authorities Having Jurisdiction should be consulted in all cases as to the particular requirements covering the installation and use of UL Certified products, equipment, system, devices, and materials.
- Authorities Having Jurisdiction should be consulted before construction.
- Fire resistance assemblies and products are developed by the design submitter and have been investigated by UL for compliance with applicable requirements. The published information cannot always address every construction nuance encountered in the field.
- When field issues arise, it is recommended the first contact for assistance be the technical service staff provided by the product manufacturer noted for the design. Users of fire resistance assemblies are advised to consult the general Guide Information for each product category and each group of assemblies. The Guide Information includes specifics concerning alternate materials and alternate methods of construction.
- Only products which bear UL's Mark are considered Certified.

BXUV - Fire Resistance Ratings - ANSI/UL 263 Certified for United States

BXUV7 - Fire Resistance Ratings - CAN/ULC-S101 Certified for Canada

See General Information for Fire-resistance Ratings - ANSI/UL 263 Certified for United States Design Criteria and Allowable Variances

See General Information for Fire Resistance Ratings - CAN/ULC-S101 Certified for Canada Design Criteria and Allowable Variances

Design No. W461

December 01, 2020

Nonbearing Wall Rating — 2 Hr

*** Indicates such products shall bear the UL or cUL Certification Mark for jurisdictions employing the UL or cUL Certification (such as Canada), respectively.**

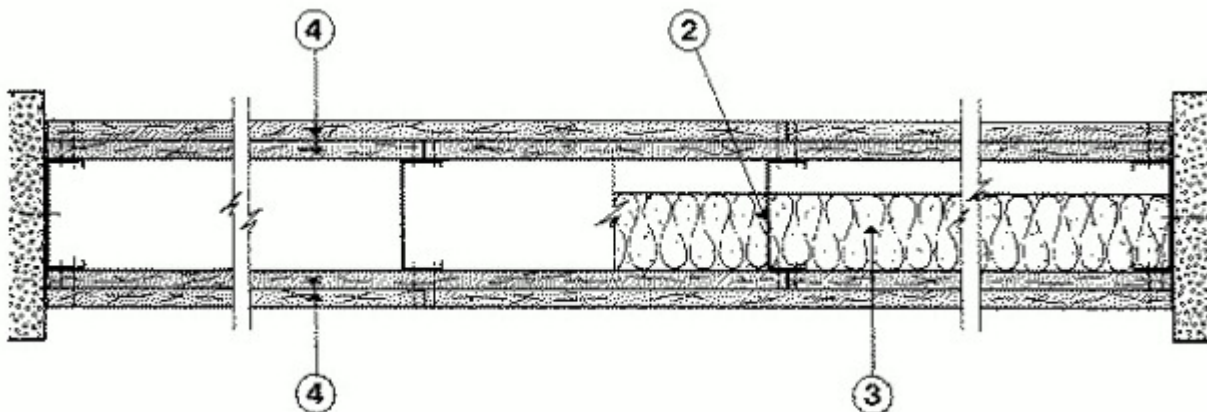

1. Floor and Ceiling Runner — (Not Shown) — Min. 25 MSG galv steel, 1 in. return legs, 2-1/2 in. deep (min), attached to floor and ceiling with fasteners 24 in. OC max.

1A. Framing Members* — Floor and Ceiling Runners — (Not Shown) — As an alternate to Item 1 - For use with Item 2A, channel shaped, min 2-1/2 in. deep, attached to floor and ceiling with fasteners 24 in. OC. max.
ALLSTEEL & GYPSUM PRODUCTS INC — Type SUPREME D24/30EQD and Type SUPREME D20

CALIFORNIA EXPANDED METAL PRODUCTS CO — Viper20™ Track

CONSOLIDATED FABRICATORS CORP, BUILDING PRODUCTS DIV — Type SUPREME D24/30EQD and Type SUPREME D20

MARINO/WARE, DIV OF WARE INDUSTRIES INC — Viper20™ Track

FUSION BUILDING PRODUCTS — Viper20™ Track

IMPERIAL MANUFACTURING GROUP INC — Viper20™ Track

QUAIL RUN BUILDING MATERIALS INC — Type SUPREME D24/30EQD and Type SUPREME D20

SCAFCO STEEL STUD MANUFACTURING CO — Type SUPREME D24/30EQD and Type SUPREME D20

STEEL CONSTRUCTION SYSTEMS INC — Type SUPREME D24/30EQD and Type SUPREME D20

TELLING INDUSTRIES L L C — Type SUPREME D24/30EQD and Type SUPREME D20

UNITED METAL PRODUCTS INC — Type SUPREME D24/30EQD and Type SUPREME D20

1B. Floor and Ceiling Runners — (Not Shown) — For use with Item 2B - Channel shaped, fabricated from min 20 MSG corrosion-protected or galv steel, min width to accommodate stud size, with min 1 in. long legs, attached to floor and ceiling with fasteners spaced max 24 in. OC.

1C. Framing Members* — Floor and Ceiling Runners — (Not Shown) — As an alternate to Item 1 - For use with Item 2C, channel shaped, min 2-1/2 in. wide fabricated from min 0.015 in. thick galv steel, attached to floor and ceiling with fasteners 24 in. OC. max.

CLARKDIETRICH BUILDING SYSTEMS — CD ProTRAK

DMFCWBS L L C — ProTRAK

MBA METAL FRAMING — ProTRAK

RAM SALES L L C — Ram ProTRAK

STEEL STRUCTURAL PRODUCTS L L C — Tri-S ProTRAK

1D. Framing Members* — Floor and Ceiling Runners — (Not Shown) — As an alternate to Item 1 - For use with Item 2D, channel shaped, min 2-1/2 in. wide fabricated from min 0.018 in. thick galv steel, attached to floor and ceiling with fasteners 24 in. OC. max.

TELLING INDUSTRIES L L C — TRUE-TRACK™

1E. Framing Members* — Floor and Ceiling Runners — (Not Shown) — As an alternate to Item 1 - For use with Item 2E, channel shaped, min 2-1/2 in. wide fabricated from min 25 MSG steel, attached to floor and ceiling with fasteners 24 in. OC. max.

KIRII (HONG KONG) LTD — Type KIRII

1F. Floor and Ceiling Runners — (Not Shown) — Channel shaped, fabricated from min 0.02 in. galv steel, min width to accommodate stud size, with min 1 in. long legs, for use with studs specified below and fabricated from min 0.018 in. galv steel or thicker, attached to floor and ceiling with fasteners spaced max 24 in. OC.

MARINO/WARE, DIV OF WARE INDUSTRIES INC — Viper20™ Track VT100

FUSION BUILDING PRODUCTS — Viper20™ Track VT100

IMPERIAL MANUFACTURING GROUP INC — Viper20™ Track VT100

1G. Framing Members* — Floor and Ceiling Runners — (Not Shown) — As an alternate to Item 1 - For use with Item 2G, channel shaped, min 2-1/2 in. deep, attached to floor and ceiling with fasteners 24 in. OC. max.

TELLING INDUSTRIES L L C — Viper20™ Track

1H. Framing Members* — Floor and Ceiling Runners — (Not Shown) — As an alternate to Item 1 - For use with Item 2J. Channel shaped, attached to floor and ceiling with fasteners 24 in. OC. max.

BAILEY METAL PRODUCTS LTD — Type PLATINUM PLUS

1I. Framing Members* — Floor and Ceiling Runners — (Not Shown) — As an alternate to Item 1 - For use with Item 2K, channel shaped, min 3-1/2 in. wide fabricated from min 0.018 in. thick galv steel, attached to floor and ceiling with fasteners 24 in. OC. max.

RESCUE METAL FRAMING, L L C — AlphaTRAK

1J. Framing Members* — Floor and Ceiling Runners — (Not Shown) — As an alternate to Item 1 - For use with Item 2L. Channel shaped, attached to floor and ceiling with fasteners 24 in. OC. max.

OEG BUILDING MATERIALS — OEG Track

1K. Framing Members* — Floor and Ceiling Runners — (Not Shown) — As an alternate to Item 1 - For use with Item 2M, channel shaped, min 2-1/2 in. wide, attached to floor and ceiling with fasteners 24 in. OC. max.

ALLSTEEL & GYPSUM PRODUCTS INC — Type SUPREME D25

CONSOLIDATED FABRICATORS CORP, BUILDING PRODUCTS DIV — Type SUPREME D25

QUAIL RUN BUILDING MATERIALS INC — Type SUPREME D25

SCAFCO STEEL STUD MANUFACTURING CO — Type SUPREME D25

STEEL CONSTRUCTION SYSTEMS INC — Type SUPREME D25

TELLING INDUSTRIES L L C — Type SUPREME D25

UNITED METAL PRODUCTS INC — Type SUPREME D25

2. **Steel Studs** — Min 2-1/2 in. deep, formed of min 25 MSG galv steel max stud spacing 24 in. OC. Studs to be cut 3/4 in. less than assembly height.

2A. **Framing Members* — Steel Studs** — As an alternate to Item 2 — For use with Item 1G, channel shaped studs, min 2-1/2 in. deep, spaced a max of 24 in. OC. Studs to be cut 3/4 in. less than assembly height.

ALLSTEEL & GYPSUM PRODUCTS INC — Type SUPREME D24/30EQD and Type SUPREME D20

CALIFORNIA EXPANDED METAL PRODUCTS CO — Viper20™

CONSOLIDATED FABRICATORS CORP, BUILDING PRODUCTS DIV — Type SUPREME D24/30EQD and Type SUPREME D20

MARINO/WARE, DIV OF WARE INDUSTRIES INC — Viper20™

FUSION BUILDING PRODUCTS — Viper20™

IMPERIAL MANUFACTURING GROUP INC — Viper20™

QUAIL RUN BUILDING MATERIALS INC — Type SUPREME D24/30EQD and Type SUPREME D20

SCAFCO STEEL STUD MANUFACTURING CO — Type SUPREME D24/30EQD and Type SUPREME D20

STEEL CONSTRUCTION SYSTEMS INC — Type SUPREME D24/30EQD and Type SUPREME D20

TELLING INDUSTRIES L L C — Type SUPREME D24/30EQD and Type SUPREME D20

UNITED METAL PRODUCTS INC — Type SUPREME D24/30EQD and Type SUPREME D20

2B. **Steel Studs** — (As an alternate to Item 2, For use with Item 4A, 4B, and 4C lead backed boards) — Channel shaped, fabricated from min 20 MSG corrosion-protected or galv steel, 3-1/2 in. min depth, spaced a max of 16 in. OC. Studs friction-fit into floor and ceiling runners. Studs to be cut 5/8 to 3/4 in. less than assembly height.

2C. **Framing Members* — Steel Studs** — As an alternate to Item 2 — For use with Item 1C, channel shaped studs, min 2-1/2 in. wide fabricated from min 0.015 in. thick galv steel, spaced a max of 24 in. OC. Studs to be cut 3/4 in. less than assembly height.

CLARKDIETRICH BUILDING SYSTEMS — CD ProSTUD

DMFCWBS L L C — ProSTUD

MBA METAL FRAMING — ProSTUD

RAM SALES L L C — Ram ProSTUD

STEEL STRUCTURAL PRODUCTS L L C — Tri-S ProSTUD

2D. **Framing Members*** — **Steel Studs** — As an alternate to Item 2 — For use with Item 1D, channel shaped studs, min 2-1/2 in. wide fabricated from min 0.018 in. thick galv steel, spaced a max of 24 in. OC. Studs to be cut 3/4 in. less than assembly height.

TELLING INDUSTRIES L L C — TRUE-STUD™

2E. **Framing Members*** — **Steel Studs** — As an alternate to Item 2 — For use with Item 1E, channel shaped studs, min 2-1/2 in. wide fabricated from min 25 MSG steel, spaced a max of 24 in. OC. Studs to be cut 3/4 in. less than assembly height.

KIRII (HONG KONG) LTD — Type KIRII

2F. **Framing Members*** — **Steel Studs** — As an alternate to Item 2 — For use with Item 1G, channel shaped studs, min 2-1/2 in. deep, spaced a max of 24 in. OC. Studs to be cut 3/4 in. less than assembly height.

TELLING INDUSTRIES L L C — Viper20™

2G. **Framing Members*** — **Steel Studs** — As an alternate to Item 2 — For use with Item 1, channel shaped studs, Min 2-1/2 in. deep, formed of min 25 MSG galv steel max stud spacing 24 in. OC. Studs to be cut 3/4 in. less than assembly height.

EB METAL INC — NITROSTUD

2H. **Framing Members*** — **Steel Studs** — As an alternate to Item 2 — For use with Item 1, channel shaped studs, Min 2-1/2 in. deep, formed of min 25 MSG galv steel max stud spacing 24 in. OC. Studs to be cut 3/4 in. less than assembly height.

OLMAR SUPPLY INC — PRIMESTUD

2I. **Framing Members*** — **Steel Studs** — As an alternate to Item 2 — For use with Item 1A (3-5/8 in. wide track), channel shaped studs, fabricated from min 25 MSG corrosion-protected steel, 1-1/4 in. wide by 3-5/8 in. deep, spaced a max of 24 in. OC. Studs to be cut 3/8 to 3/4 in. less than assembly height.

MARINO/WARE, DIV OF WARE INDUSTRIES INC — StudRite™

2J. **Framing Members*** — **Steel Studs** — As an alternate to Item 2 — For use with Item 1H, channel shaped, min 3-5/8 in. wide, spaced a max of 24 in. OC. Studs to be cut 3/8 to 3/4 in. less than assembly height.

BAILEY METAL PRODUCTS LTD — Type PLATINUM PLUS

2K. **Framing Members*** — **Steel Studs** — As an alternate to Item 2 — For use with Item 1I, channel shaped studs, min 3-1/2 in. wide fabricated from min 0.018 in. thick galv steel, spaced a max of 24 in. OC. Studs to be cut 3/4 in. less than assembly height.

RESCUE METAL FRAMING, L L C — AlphaSTUD

2L. **Framing Members*** — **Steel Studs** — As an alternate to Item 2 — For use with Item 1J, channel shaped studs, Min 2-1/2 in. deep, formed of min 25 MSG galv steel max stud spacing 24 in. OC. Studs to be cut 3/8 to 3/4 in. less than assembly height.

OEG BUILDING MATERIALS — OEG Stud

2M. Framing Members* — Steel Studs — As an alternate to Item 2 — For use with Item 1K, channel shaped studs, min 2-1/2 in. wide, spaced a max of 24 in. OC. Studs to be cut 3/4 in. less than assembly height.

ALLSTEEL & GYPSUM PRODUCTS INC — Type SUPREME D25

CONSOLIDATED FABRICATORS CORP, BUILDING PRODUCTS DIV — Type SUPREME D25

QUAIL RUN BUILDING MATERIALS INC — Type SUPREME D25

SCAFCO STEEL STUD MANUFACTURING CO — Type SUPREME D25

STEEL CONSTRUCTION SYSTEMS INC — Type SUPREME D25

TELLING INDUSTRIES L L C — Type SUPREME D25

UNITED METAL PRODUCTS INC — Type SUPREME D25

3. Batts and Blankets* — (Optional) — Mineral wool or glass fiber batts partially or completely filling stud cavity.

See **Batts and Blankets** (BZJZ) category for names of manufacturers.

3A. Fiber, Sprayed* — As an alternate to Batts and Blankets (Item 3) — (100% Borate Formulation) — Spray applied cellulose material. The fiber is applied with water to completely fill the enclosed cavity in accordance with the application instructions supplied with the product with a nominal dry density of 2.7 lb/ft³. Alternate Application Method: The fiber is applied without water or adhesive at a nominal dry density of 3.5 lb/ft³, in accordance with the application instructions supplied with the product.

U S GREENFIBER L L C — INS735, INS745 and INS750LD for use with wet or dry application. INS765LD and INS773LD are to be used for dry application only.

3B. Fiber, Sprayed* — As an alternate to Batts and Blankets (Item 3) — Spray applied cellulose insulation material. The fiber is applied with water to interior surfaces in accordance with the application instructions supplied with the product. Applied to completely fill the enclosed cavity. Minimum dry density of 4.3 pounds per cubic ft.

NU-WOOL CO INC — Cellulose Insulation

3C. Fiber, Sprayed* — As an alternate to Batts and Blankets (Item 3) — Spray applied cellulose fiber. The fiber is applied with water to completely fill the enclosed cavity in accordance with the application instructions supplied with the product. The minimum dry density shall be 4.30 lbs/ft³.

INTERNATIONAL CELLULOSE CORP — Celbar-RL

4. Gypsum Board* — Two layers of 5/8 in. thick gypsum boards applied vertically or horizontally (except for type LGLLX which is applied vertically only). Inner layer attached to studs with #6 x 1 in. long bugle head screws spaced 12 in. OC along the top and bottom tracks and 16 in. OC in the field and along the vertical edges. Outer layer attached to studs with #6 x 1-5/8 in. long bugle head screws spaced 12 in. OC along the top and bottom tracks and 16 in. OC in the field and along the vertical edges. Vertical joints are centered over studs and staggered between layers and on opposite sides of the wall. Horizontal joints on the face layer are staggered 12 in. from the base layer. Horizontal joints need not to be backed by steel framing.

a. As an alternate - Two layers of 1/2 thick gypsum boards applied vertically, or inner layer gypsum board applied vertically, outer layer wallboard applied horizontally. Inner layer attached to studs with 1 in. Type S steel screws spaced 24 in. O.C. along vertical edges and in the field. When outer layer is applied horizontally, outer layer attached to the studs over the inner layer with 1-5/8 in. long Type S steel screws spaced 12 in. OC in the field, along the vertical edges, and to the floor and ceiling

runners. Outer layer secured to inner layer gypsum board with 1-1/2 in. long Type G steel screws located midway between studs and 1 in. from the horizontal joint. Outer layer gypsum board joints covered with joint tape and min two coats of joint compound, and screw heads covered with min two coats of joint compound. Joints reinforced.

b. As an alternate - Inner layer of 1/2 in. thick gypsum board applied vertically to studs with 1 in. Type S steel screws spaced 24 in. OC along vertical edges and in the field. Outer layer of 5/8 in. thick gypsum board applied either vertically or horizontally, and attached to studs with 1-5/8 in. long Types S steel screws spaced 12 in. OC in the field, along the vertical edges and to the floor and ceiling runners.

c. As an alternate - Inner layer of 5/8 in. thick board applied either vertically or horizontally to studs with 1 in. long Type S steel screws spaced 24 in. OC along the vertical edges and in the field. Outer layer of 1/2 in. thick board applied vertically and attached to studs with 1-5/8 in. long Type S steel screws spaced 12 in. OC in the field, along the vertical edges, and to the floor and ceiling runners.

CONTINENTAL BUILDING PRODUCTS OPERATING CO, L L C — 1/2 in. thick Type LGFC-C/A, and 5/8 in. thick Types LGFC-C/A, LGFC2A, LGFC6A, LGFC-WD and LGLLX (Type LGLLX to be applied vertically only)

4A. **Gypsum Board*** — (Not Shown) — (As an alternate to Item 4 when used as the base layer on one or both sides of wall. For direct attachment only to steel studs Item 2B) — Nom 5/8 in. thick lead backed gypsum panels with beveled, square or tapered edges, applied vertically. Vertical joints centered over studs and staggered min 1 stud cavity on opposite sides of studs. Gypsum board secured to studs with 1-1/4 in. long Type S-12 steel screws spaced 8 in. OC at perimeter and 12 in. OC in the field.

RAY-BAR ENGINEERING CORP — Type RB-LBG

4B. **Gypsum Board*** — (Not Shown) — (As an alternate to Item 4 when used as the base layer on one or both sides of wall. For direct attachment only to steel studs Item 2B) — Nom 5/8 in. thick lead backed gypsum panels with beveled, square or tapered edges, applied vertically. Vertical joints centered over studs and staggered min 1 stud cavity on opposite sides of studs. Wallboard secured to studs with 1-5/8 in. long Type S 12 steel screws spaced 8 in. OC at perimeter and 12 in OC in the field. Lead batten strips required behind vertical joints of lead backed gypsum wallboard and optional at remaining stud locations. Fasteners for face layer gypsum panels when installed over lead backed board to be min 2-1/2 in. Type S-12 bugle head steel screws spaced as described in Item 4. To be used with Lead Batten Strips (see Item 5A) or Lead Discs (see Item 6A).

MAYCO INDUSTRIES INC — Type X-Ray Shielded Gypsum

4C. **Gypsum Board*** — (As an alternate to Item 4 when used as the base layer on one or both sides of wall. For direct attachment only to steel studs Item 2B) — Nom 5/8 in. thick lead backed gypsum panels with beveled, square or tapered edges, applied vertically. Vertical joints centered over studs and staggered min 1 stud cavity on opposite sides of studs. Wallboard secured to studs with 1-1/4 in. long Type S-12 steel screws gypsum panel steel screws spaced 8 in. OC at perimeter and 12 in. OC in the field. Lead batten strips required behind vertical joints of lead backed gypsum wallboard and optional at remaining stud locations. Lead batten strips, min 2 in. wide, max 8 ft long with a max thickness of 0.14 in. placed on the face of studs and attached to the stud with construction adhesive and two 1 in. long Type S-12 pan head steel screws, one at the top of the strip and one at the bottom of the strip. Lead discs, nominal 3/8 in. diam by max 0.085 in. thick. Compression fitted or adhered over the screw heads. Lead batten strips and discs to have a purity of 99.9% meeting the Federal specification QQ-L-201f, Grade "C".

RADIATION PROTECTION PRODUCTS INC — Type RPP - Lead Lined Drywall

5. **Lead Batten Strips** — (Not Shown, For Use With Item 4A) — Lead batten strips, min 1-1/2 in. wide, max 10 ft long with a max thickness of 0.125 in. Strips placed on the interior face of studs and attached from the exterior face of the stud with two 1 in. long Type S-12 pan head steel screws, one at the top of the strip and one at the bottom of the strip. Lead batten strips to have a purity of 99.9% meeting the Federal specification QQ-L-201f, Grade "C". Lead batten strips required behind vertical joints of lead backed gypsum board (Item 4D) and optional at remaining stud locations. Required behind vertical joints.

5A. **Lead Batten Strips** — (Not Shown, for use with Item 4B) — Lead batten strips, 2 in. wide, max 10 ft long with a max thickness of 0.140 in. Strips placed on the face of studs and attached to the stud with two min. 1 in. long min. Type S-8 pan head steel screws, one at the top of the strip and one at the bottom of the strip or with one min. 1 in. long min. Type S-8 pan head steel screw at the top of the strip. Lead batten strips to have a purity of 99.5% meeting the Federal specification QQ-L-201f, Grades "B, C or D". Lead batten strips required behind vertical joints of lead backed gypsum wallboard (Item 6) and optional at remaining stud locations.

6. **Lead Discs or Tabs** — (Not Shown, For Use With Item 4A) — Used in lieu of or in addition to the lead batten strips (Item 5) or optional at other locations - Max 3/4 in. diam by max 0.125 in. thick lead discs compression fitted or adhered over steel screw heads or max 1/2 in. by 1-1/4 in. by max 0.125 in. thick lead tabs placed on gypsum boards (Item 4D) underneath screw locations prior to the installation of the screws. Lead discs or tabs to have a purity of 99.9% meeting the Federal specification QQ-L-201f, Grade "C".

6A. **Lead Discs** — (Not Shown, for use with Item 4B) — Max 5/16 in. diam by max 0.140 in. thick lead discs compression fitted or adhered over steel screw heads. Lead discs to have a purity of 99.5% meeting the Federal Specification QQ-L-201f, Grades "B, C or D".

7. **Mineral and Fiber Board*** — (Optional, Not Shown) — For optional use as an additional layer on one side of wall. Nom 1/2 in. thick, 4 ft wide with long dimension parallel and centered over studs. Attached to studs and floor and ceiling runners with 1-5/8 in. long Type S steel screws, spaced 12 in. OC. The required UL Classified gypsum board layer(s) is/are to be installed as indicated as to fastener type and spacing, except that the required fastener length shall be increased by a minimum of 1/2 in. Not evaluated or intended as a substitute for the required layer(s) of UL Classified Gypsum Board.

HOMASOTE CO — Homasote Type 440-32

8. **Furring Channels** — (Optional, Not Shown — not for use with Items 4A, 4B, or 4C) — Resilient furring channels fabricated from min 25 MSG corrosion-protected steel, spaced vertically a max of 24 in. OC. Flange portion attached to each intersecting stud with 1/2 in. long Type S-12 steel screws.

8A. **Framing Members*** — (Optional on one or both sides, Not Shown — not for use with Items 4D, 4H, 4J, or 4N) — As an alternate to Item 8, furring channels and Steel Framing Members as described below:

a. **Furring Channels** — Formed of No. 25 MSG galv steel. 2-9/16 in. or 2-23/32 in. wide by 7/8 in. deep, spaced max. 24 in. OC perpendicular to studs. Channels secured to studs as described in Item b.

b. **Steel Framing Members*** — Used to attach furring channels (Item 8Aa) to studs. Clips spaced max. 48 in. OC. RSIC-1 and RSIC-1 (2.75) clips secured to studs with No. 8 x 1-1/2 in. minimum self-drilling, S-12 steel screw through the center grommet. RSIC-V and RSIC-V (2.75) clips secured to studs with No. 8 x 9/16 in. minimum self-drilling, S-12 steel screw through the center hole. Furring channels are friction fitted into clips. RSIC-1 and RSIC-V clips for use with 2-9/16 in. wide furring channels. RSIC-1 (2.75) and RSIC-V (2.75) clips for use with 2-23/32 in. wide furring channels.

PAC INTERNATIONAL L L C — Types RSIC-1, RSIC-V, RSIC-1 (2.75), RSIC-V (2.75)

8B. **Framing Members*** — (Optional on one or both sides, Not Shown — Not for use with Items 4D, 4H, 4J, or 4N) — As an alternate to Item 8, furring channels and Steel Framing Members as described below:

a. **Furring Channels** — Formed of No. 25 MSG galv steel. Spaced 24 in. OC perpendicular to studs. Channels secured to studs as described in Item b. Ends of adjoining channels overlapped 6 in. and tied together with double strand of No. 18 AWG galvanized steel wire. Gypsum board attached to furring channels as described in Item 4.

b. **Steel Framing Members*** — Used to attach furring channels (Item a) to studs. Clips spaced 48 in. OC., and secured to studs with 2 in. coarse drywall screw with 1 in. diam washer through the center hole. Furring channels are friction fitted into clips.

STUDCO BUILDING SYSTEMS — RESILMOUNT Sound Isolation Clips - Type A237R

9. **Barrier Mesh** — (Optional, Not Shown) - Attached to steel studs on one or both sides of the wall using Barrier Mesh Clips spaced at maximum 12 inches on center vertically, using a flat head type screw penetrating through the steel at least 3/8 of an inch. For Steel Studs less than 0.033 inches in thickness, use self-piercing screws. For Steel Studs equal to or greater than 0.033 inches in thickness, use steel drill screws (self-tapping). Gypsum Board (Item 45) to be installed directly over the Barrier Mesh using prescribed screw patterns with lengths increased by a minimum 1/8 in. Barrier Mesh may be installed with the long dimension of the diamond pattern positioned vertically or horizontally. Barrier Mesh joints may occur as butt joints at the framing members and secured using the Barrier Mesh Clips or occur in between framing members as overlapping joints secured using 18 SWG wire ties spaced a maximum 12 in. on center.

CLARKDIETRICH BUILDING SYSTEMS — Barrier Mesh, Barrier Mesh Clips

*** Indicates such products shall bear the UL or cUL Certification Mark for jurisdictions employing the UL or cUL Certification (such as Canada), respectively.**

Last Updated on 2020-12-01

The appearance of a company's name or product in this database does not in itself assure that products so identified have been manufactured under UL's Follow-Up Service. Only those products bearing the UL Mark should be considered to be Certified and covered under UL's Follow-Up Service. Always look for the Mark on the product.

UL permits the reproduction of the material contained in the Online Certification Directory subject to the following conditions: 1. The Guide Information, Assemblies, Constructions, Designs, Systems, and/or Certifications (files) must be presented in their entirety and in a non-misleading manner, without any manipulation of the data (or drawings). 2. The statement "Reprinted from the Online Certifications Directory with permission from UL" must appear adjacent to the extracted material. In addition, the reprinted material must include a copyright notice in the following format: "© 2020 UL LLC"